



Wrangler Replay Top with Tinted Windows

Installation Instructions

For: Jeep Wrangler Unlimited (JK) 4 Door
2007 and Newer

Part Number: 51201



Installation Tips

Before you begin installing this assembly, read all instructions thoroughly.

For a smooth fit:

For ease in installation, the product should be installed at temperatures above 72° F. Below this temperature, the fabric may contract an inch or more, making it difficult to fit to the vehicle. It is normal for fabric to contract and wrinkle when stored in the shipping carton. Within a few days after the installation, the fabric will relax and the wrinkles will disappear.



WARNING

This product is designed to enhance the appearance of the vehicle. Do not rely in any way on the components of this product to contain occupants within the vehicle, or to protect against injury or death in the event of an accident. Never operate vehicle in excess of manufacturer's specifications.

WEAR SEAT BELTS AT ALL TIMES

Read and follow, precisely, all installation instructions provided when installing this product. Failure to do so could place occupants of the vehicle in a potentially dangerous situation. After installing or reinstalling, check to make sure it has been properly installed.

Table of Contents

WRANGLER REPLAY TOP PARTS LIST.....	PAGE 2
WRANGLER REPLAY TOP TOOLS NEEDED	PAGE 2
WRANGLER REPLAY TOP INSTALLATION.....	PAGE 2
WRANGLER REPLAY TOP WARRANTY	PAGE 9



CAUTION

Safety glasses should be worn at all times while installing this product.

Tools Needed

Safety Glasses
Phillips Screwdriver
Masking Tape

Parts List

Fabric Top	Qty - 1
Quarter Window, Right	Qty - 1
Quarter Window, Left	Qty - 1
Rear Window	Qty - 1
Elastic Garter	Qty - 2

Step Two

RELEASE WINDSHIELD LATCHES

Release the latch that secures the header to the windshield. Pull up on the lever and then down and out to release the hook from the loop in the windshield frame.

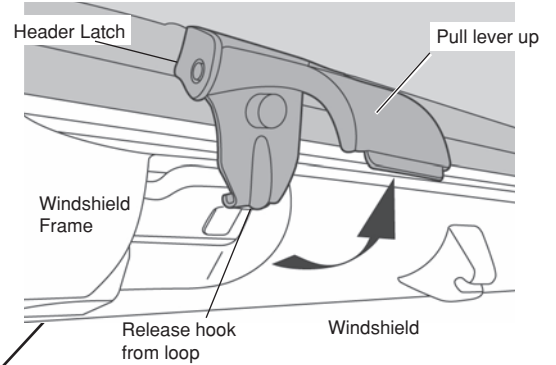

Step One

REMOVE QUARTER WINDOWS AND REAR WINDOW

Remove the Quarter Windows and the Rear Window. Remove the metal Tailgate Bar from the bottom of the Rear Window and set it aside.

Release the plastic strip sewn to the top above the doors. Pull down and out to slip the plastic out of the channel.

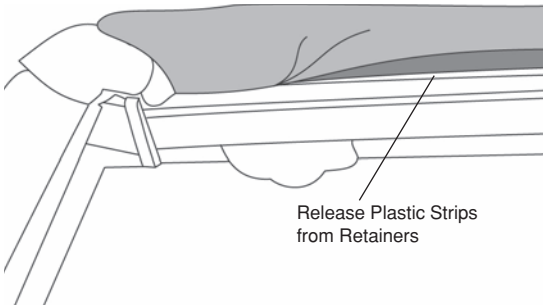

Release Plastic Strips from Retainers

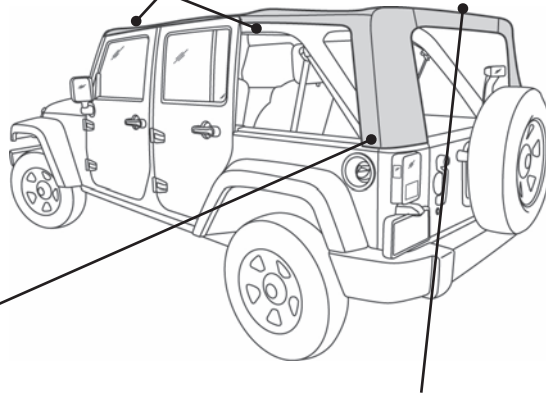

Step Three

RELEASE REAR CORNERS

Release the rear corners of the top. Pull gently down and then out to release the plastic strip from the retainer on the vehicle.

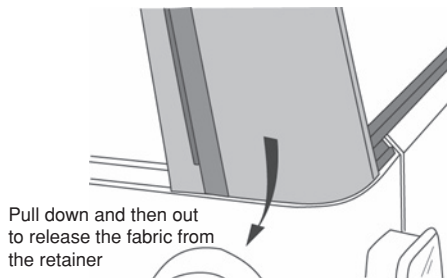

Pull down and then out to release the fabric from the retainer

Step Four

RELEASE REAR 2 BOWS

Use a phillips screwdriver to remove the four screws that attach the flaps in the top to the two Rear Bows. Set the screws aside to be reused later. Allow the bows to drop onto the tailgate.

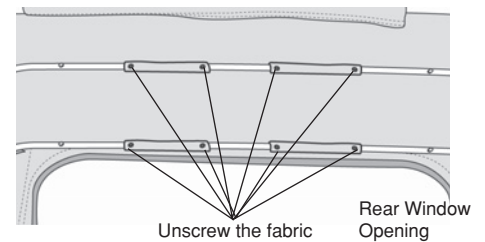

View from inside vehicle

Step Five

UNFASTEN CENTER BOW

Unfasten the hook and loop flaps around the Bows on each side of the sport bar.

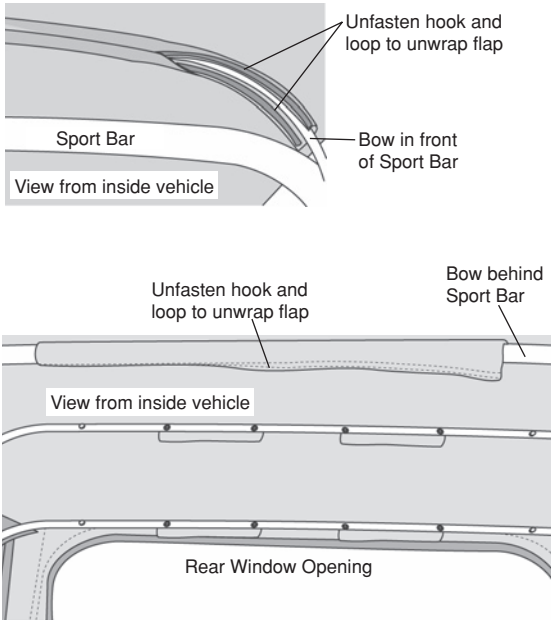

Step Six

REMOVE HEADER SCREWS

Collapse the bow assembly down onto the tailgate to access the header. Remove the two screws that secure the fabric to the header.

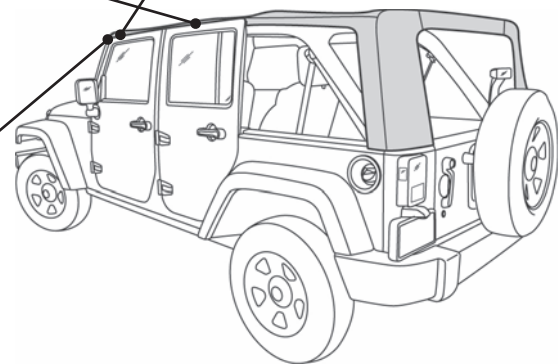
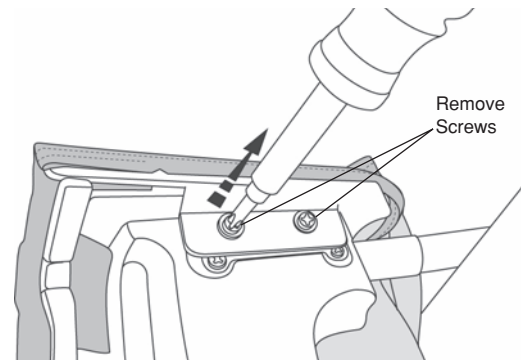

Step Seven

REMOVE TOP FABRIC

Raise the bow assembly and lock the header to the windshield. Drape the top fabric, backing side up, over the hood and windshield. Remove the nineteen (19) screws that secure the fabric to the upper and lower headers. Set the screws aside for use in installing the new top. Slide the extrusion along the front edge of the top out of the channel in the lower header and remove the old top from the vehicle.

Top Fabric - Backing Side Up

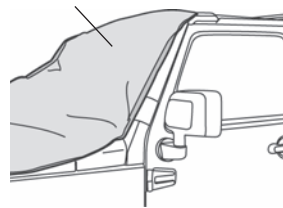

Remove Screws (19) Across Header

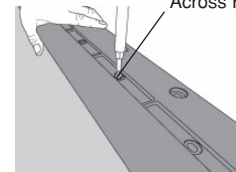

Slide Extrusion along the Front Edge of the Channel to remove Top

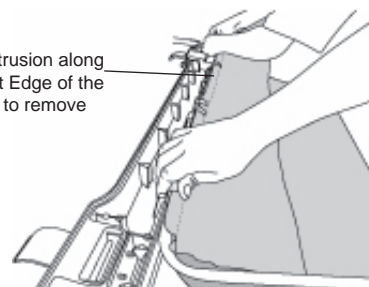

Step Eight

INSTALL TOP FABRIC

Raise the bow assembly and lock the header to the windshield.

Drape the top fabric, backing side up, over the hood and windshield. Slide the extrusion along the front edge of the top into the channel in the lower header. Line up the center notch in the fabric with the center notch in the header. Use masking tape to help hold the fabric in place along the lower header.

Top Fabric - Backing Side Up

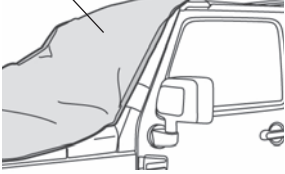

Slide Extrusion along the Front Edge of the Channel

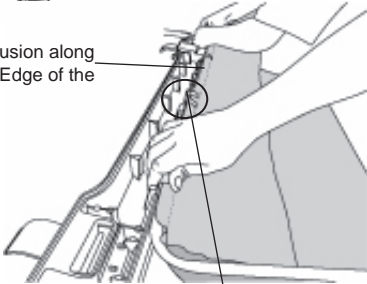

Line up the Center Notch in the Fabric with the Center Notch in the Header

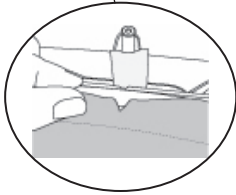

Step Nine

INSTALL TOP FABRIC

Close the upper header over the fabric, sandwiching the fabric. Reinstall the four (4) corner screws. Then install the nineteen (19) screws across the header.

Lower the bow assembly to the rear of the vehicle.

Reinstall Corner Screws

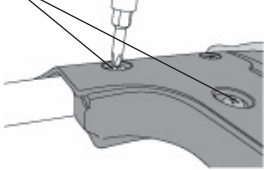

Install Screws Across Header

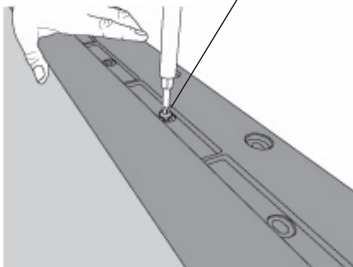

Step Ten

INSTALL CORNER SCREWS

Wrap the fabric around the header and raise the header slightly to work the pockets in the fabric over the corners of the header. Install the screws removed in Step 6 in each corner to secure the fabric to the header.

Install Screws

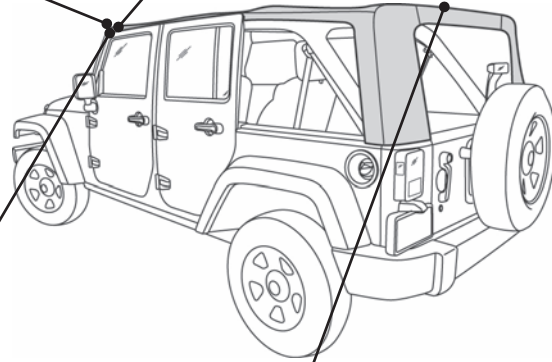
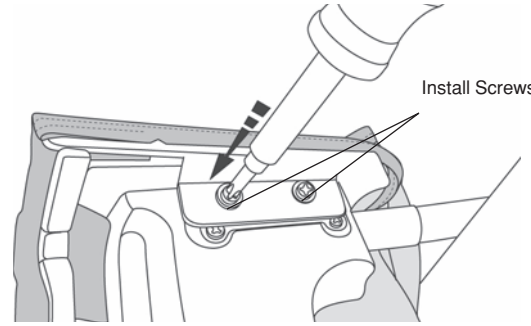

Step Eleven

ATTACH TOP TO REAR 2 BOWS

Raise the header and bow slightly to allow you to attach the rear bow flaps, that are inside the top above the rear window opening, to the rear bow. Use the screws that were removed in Step 5 to secure the flaps to the bow. Then secure the flaps to the bow in front of the rear bow.

Rear Bows

Screw Flaps to Rear 2 Bows

View from inside vehicle

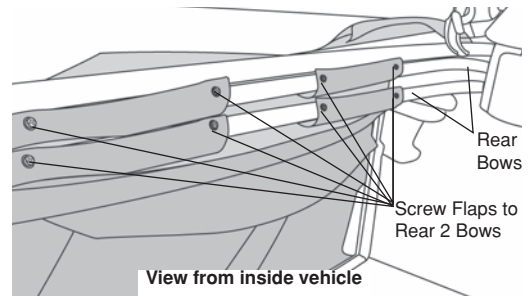

Step Twelve

SECURE CENTER BOWS

Wrap the hook and loop flaps around the two Bows in the center of the top.

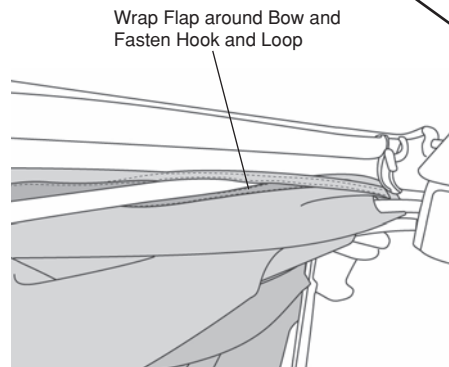
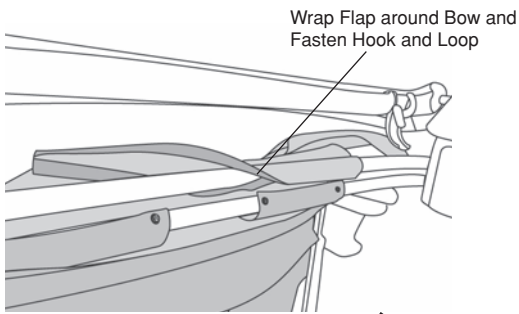

Step Thirteen

INSTALL BOW ASSEMBLY

Open the Top Assembly and drape it over the cab of the vehicle.

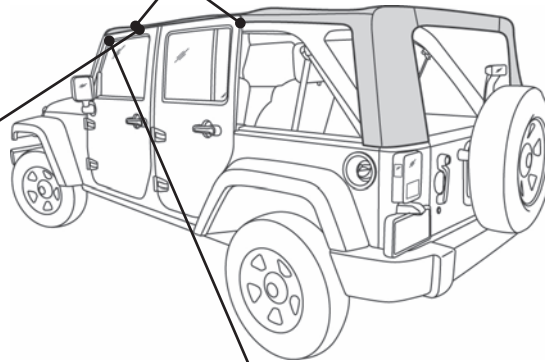

Step Fourteen

SECURE BOW ASSEMBLY

Slide the Pivot Assembly on the Top along the track above the door until it latches into place..

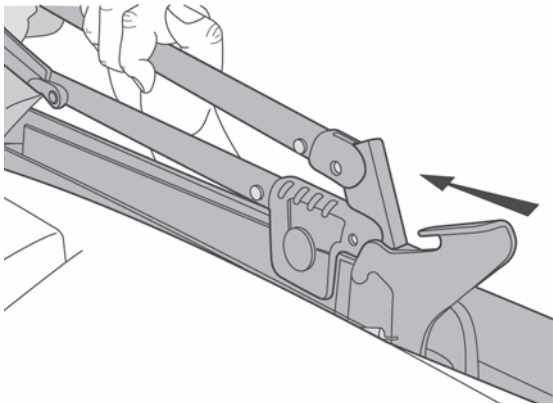

Step Fifteen

SECURE HEADER TO WINDSHIELD

Close the header latches to secure the front of the top to the windshield. Catch the hook in the loop in the windshield frame and then close the lever over it so that it lays flat against the windshield frame.

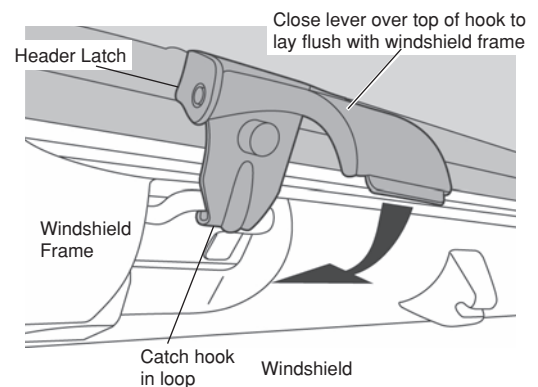

Step Sixteen

SECURE REAR CORNERS

Pull down gently on the Rear Bow and work the plastic sewn to the rear corners of the top into the retainer on the vehicle.

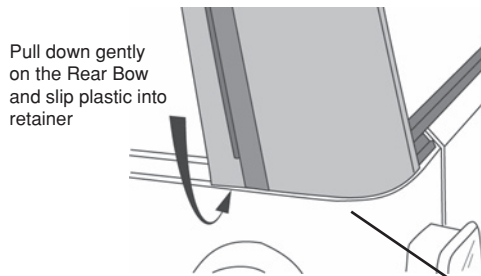

Step Twenty

SECURE TOP ABOVE DOOR OPENINGS

Slip the plastic strips above the doors into the channel on the vehicle.

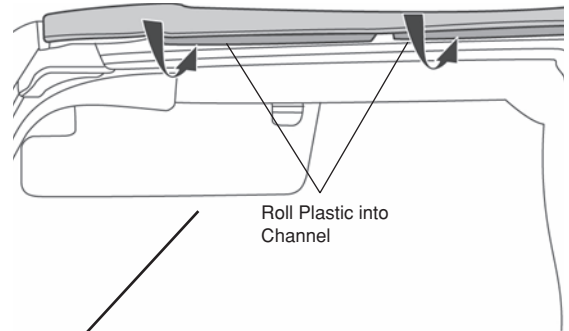

Step Seventeen

ATTACH QUARTER WINDOW ZIPPERS

Start the zipper on the Quarter Window and close it 1-2 inches.

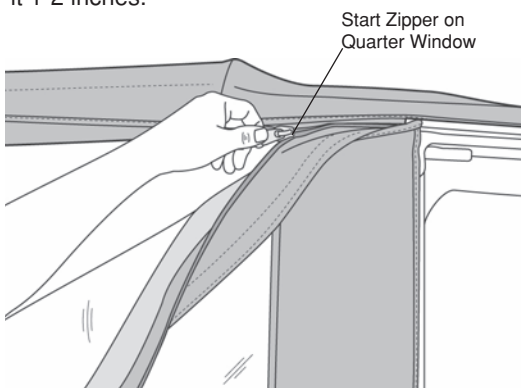

Step Eighteen

SECURE FRONT OF QUARTER PANELS

Roll the plastic strip along the front of the Quarter Window into the channel in the Door Surround.

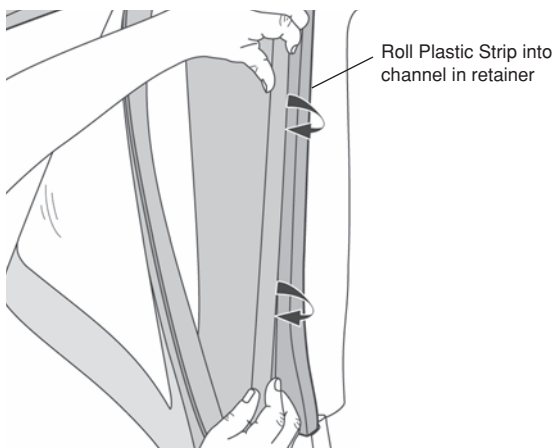

Step Nineteen

SECURE QUARTER WINDOWS

Close the zipper and slip the plastic along the bottom of the Side Window into the channel on the vehicle.

Fasten the hook and loop strip above the window to the top.

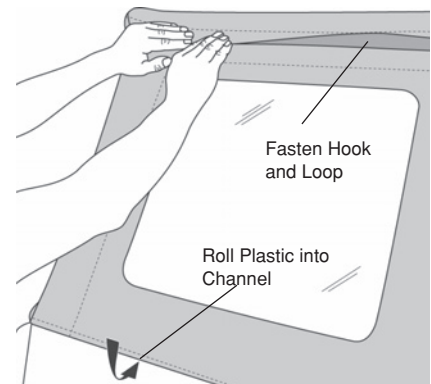

Step Twenty-one

INSTALL TAILGATE BAR ON REAR WINDOW

Snap the Elastic Garters to the snaps on the Rear Bow above the rear window opening.

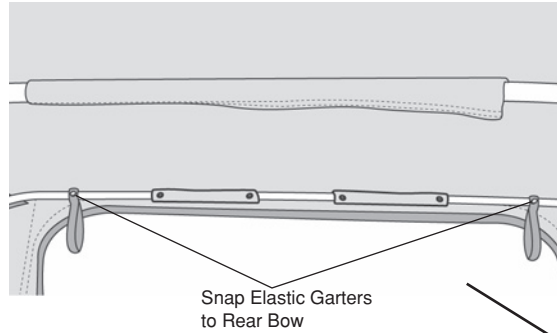

Step Twenty-two

INSTALL TAILGATE BAR ON REAR WINDOW

Remove the Rear Window from the box and lay it flat with the backing side up. Locate the Tailgate Bar set aside in Step One. The bar has a "C" shaped channel, when viewed from the end. Orient the bar with the round seal down and slide the "C" channel on the retainer onto the tubed strip sewn to the backing side of the Rear Window.

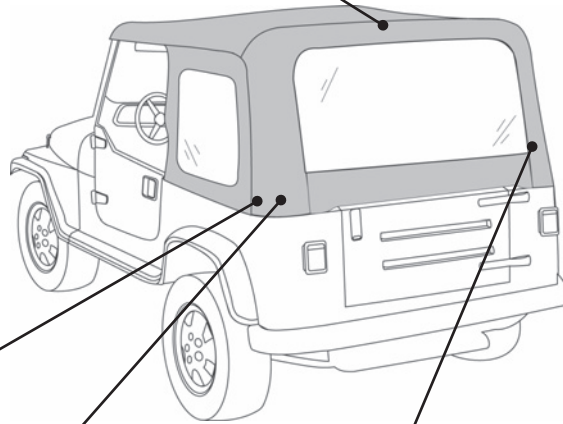
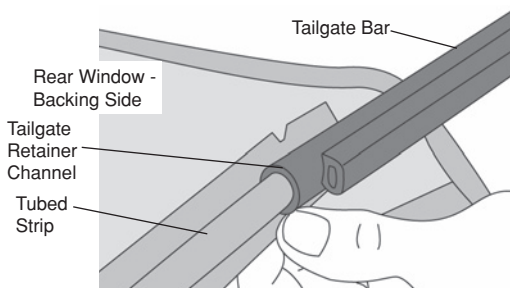

Step Twenty-four

SECURE REAR WINDOW ZIPPERS

To start the zipper, pull the two sliders as far down as possible on the driver's side of the window in order to catch the sliders to the pin.

Once the zipper is caught, start the top slider 1/2". Then hold up the top of the window with one hand and close the zipper with the other. The zipper is sandwiched between layers of fabric in the corners so be careful not to catch extra fabric in the zipper. Close the zipper.

Make sure that the Tailgate Bar is centered and is securely in the mounts. Then tuck the flaps on the Rear Window under the top fabric.

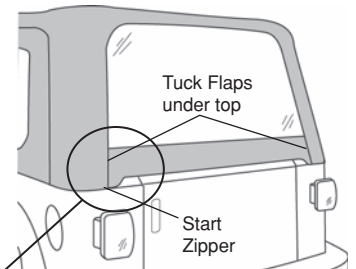

Step Twenty-three

INSTALL TAILGATE BAR ON VEHICLE

Insert the Tailgate Bar into the mounts on each side of the tailgate opening with the vinyl side of the Rear Window toward the outside of the vehicle.

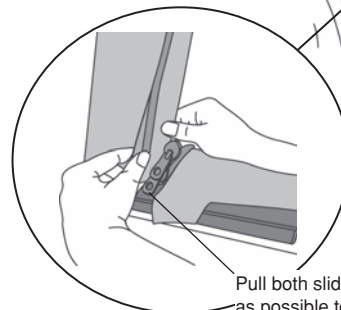
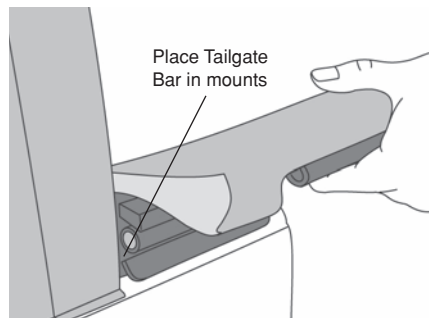

Step Twenty-five

To FOLD THE TOP DOWN

REMOVE QUARTER PANELS AND REAR WINDOW

Remove the Quarter Panels and the Rear Window. To remove the Quarter Windows, unzip the rear and top zippers. Release the plastic strip from the retainer. Release the Hook and Loop Fasteners from around the Vertical Retainer.

To roll up the Rear Window, remove the Tailgate Bar and open the zippers on each side of the window to the top. Start at the bottom and roll the window to the inside. Avoid wrinkles in the fabric and window. Secure it in place with the elastic garters inside of the top..

 **WARNING** When operating the vehicle without the Quarter Windows, the Rear Window should be rolled up and secured with the elastic garters for proper ventilation.

Step Twenty-six

To FOLD THE TOP DOWN

COLLAPSE TOP

Release the front of the top from the windshield. Raise the front of the deck and collapse the rear bows, tucking the two plastic strips above the door openings and the stay pad on the rear bow inside of the bows, Wrap the fabric around the bows, then tuck the rear legs of the top under the bows.

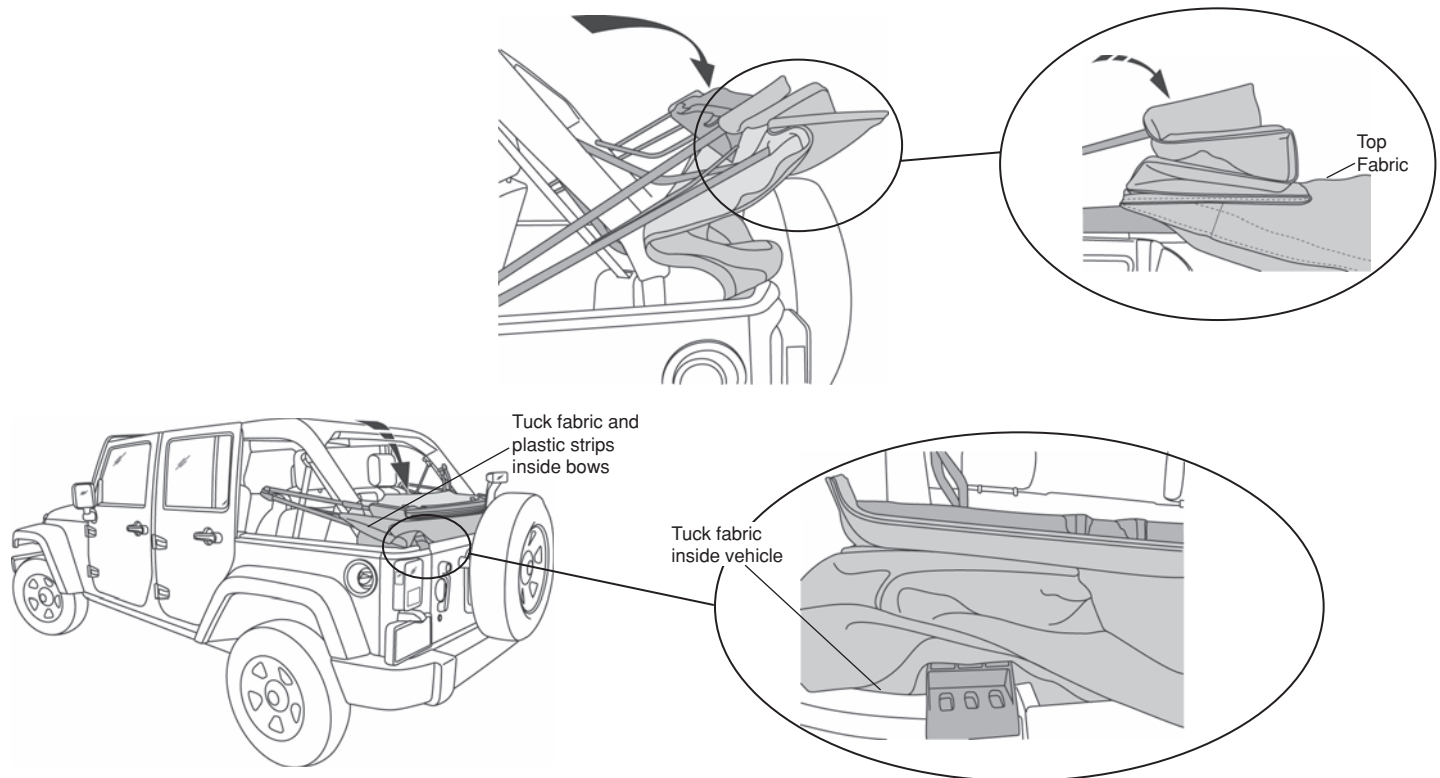

Care and Maintenance of your New Top

Your top is made of the finest materials available. To keep it looking new and for the maximum possible wear, it will need periodic cleaning and maintenance.

Washing: The fabric should be washed often using soap, warm water and a soft bristle brush. Rinse with clear water to remove all traces of soap.

Zippers: Keeping the zipper cleaned and lubricated with a silicone lubricant will help prevent damage and keep the zippers in a smooth working condition. If a zipper opens behind the slider, the slider may have been spread apart. This problem can usually be repaired by using an ordinary pair of pliers to bring the sides back into parallel. Return slider to the end of the zipper in the normal Open position. Squeeze lightly at first and test the zipper. If the zipper continues to remain open squeeze more firmly with the pliers and try the zipper again. Repeat this procedure until the zipper operates correctly.

Water: In the event of seeping through the seams, 3M Scotchgard® may be applied on the inside of the seams to stop the seepage. Rips in the fabric may be repaired with Bondex® iron on patches. Iron the patches to the Inside of the top, carefully following the Bondex® instructions.

Snaps: Keep snaps cleaned and lubricated with silicone to help prevent snaps from sticking to the studs. If a snap does become stuck to a stud, use a screwdriver and GENTLY pry apart to prevent permanent damage to the snap or the top fabric.

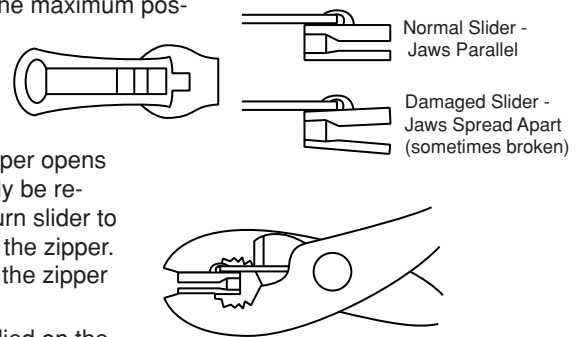

LIMITED WARRANTY

We warrant our product to be free from defects in material and workmanship, for terms specified below, provided there has been normal use and proper maintenance. This warranty applies to the original purchaser only. All remedies under this warranty are limited to the repair or replacement of any item or items found by the factory to be defective within the time period specified.

If you have a warranty claim, first you must call our factory at the number below for instructions. You must retain proof of purchase and submit a copy with any items returned for warranty work. Upon completion of warranty work, if any, we will return the repaired or replaced item or items to you freight prepaid. Damage to our products caused by accidents, fire, vandalism, negligence, misinstallation, misuse, Acts of God, or by defective parts not manufactured by us, is not covered under this warranty.

THE WARRANTY TIME PERIOD IS AS FOLLOWS: ALL "GOODS" MANUFACTURED BY OUR COMPANY: ONE YEAR FROM DATE OF PURCHASE.

ANY IMPLIED WARRANTIES OF MERCHANTABILITY AND/OR FITNESS FOR A PARTICULAR PURPOSE CREATED HEREBY ARE LIMITED IN DURATION TO THE SAME DURATION AND SCOPE AS THE EXPRESS WRITTEN WARRANTY. OUR COMPANY SHALL NOT BE LIABLE FOR ANY INCIDENTAL OR CONSEQUENTIAL DAMAGE.

Some states do not allow limitations on how long an implied warranty lasts, or the exclusion or limitation of incidental or consequential damages, so the above limitations or exclusions may not apply to you.

This warranty gives you specific legal rights, and you may also have other rights which vary from state to state.

For further information, please contact:

Customer Service
877-638-9509

All or a portion of this product may have been made in China.